

**NEW RANGE**

**DIVERTRON**

**THE NEW SHAPE OF  
EFFICIENCY**



**DAB**<sup>®</sup>  
WATER • TECHNOLOGY



# DIVERTRON

## THE NEW SHAPE OF EFFICIENCY

At DAB we listen to the needs of customers, technicians, the market and the environment. That is why we always anticipate the evolution of our products, improving their characteristics, potential and usability before all else and before it's too late.

The first generation of Divertron was developed in **2007**, breaking into the market **as a complete novelty**: it is a range of submersible pumps **with integrated on/off electronics**, a feature that has made it a product of excellence to this day.

After **15 years** and after **more than 1 million pieces installed**.

DAB's ongoing research and drive for continuous development has led it to launch **the second generation of Divertron**.

This product has been improved in terms of appearance and technical and technological content in order **to increase its performance** and **reduce its consumption**, adapting it well in advance to the next MEI regulations on **energy efficiency**.

At the same time, it has been made **even stronger** and **easier to install and maintain**.

**Find out more**



## A RENEWED PRODUCT: MORE POWERFUL AND EASIER TO USE IN ALL ITS APPLICATIONS

📍 tank installation



**STANDARD VERSION**



### FLOAT

By detecting the water level, the float prevents repeat starting routines and provides additional protection against dry running. In addition, the float also prevents the pump from becoming blocked due to a continuous lack of water.



Divertron is a submersible pump with integrated on/off electronics for domestic water supply. Ideal for irrigation and gardening and for the reuse of rainwater, it can be installed inside collecting tanks, wells and tanks with a maximum immersion depth of 12 metres.

## KIT X. Filter and ball float

Attached to the special filter designed for Version X, this accessory prevents water from being sucked up from the very bottom of a well or tank, so that sludge, dust or debris is not drawn in. The kit is ready for use because the connecting tube is already included.



### 📍 well installation



**X VERSION**



WATER BOOSTING



GARDENING & IRRIGATION



RAIN WATER REUSE

# DIVERTRON

## THE SECOND GENERATION

### LESS CONSUMPTION, MORE OUTPUT

Combining the new high-efficiency impellers and an optimised mechanical seal, **the new Divertron consumes 30% less power than the current model, while still achieving higher performance.**

**In line with the MEI directives** on energy efficiency, which will enter into force in 2024, **it helps to respect the environment and reduce energy bills.** This is a real benefit your customers will want to hear about.



### CONTINUITY OF OPERATION AND DURABILITY OVER TIME

In this new version, **the float works in conjunction with the integrated electronic card** to offer **double protection against dry running**, preventing the repetition of starting routines. This ensures superior and smooth operation and less stress on the pump, **extending its life cycle and reducing the need for special maintenance. A real long-term investment.**



### SIMPLE MAINTENANCE

The condenser can be accessed **directly** from outside in a quick and easy way, **and removed without complicated disassembly operations.** Fast and functional.

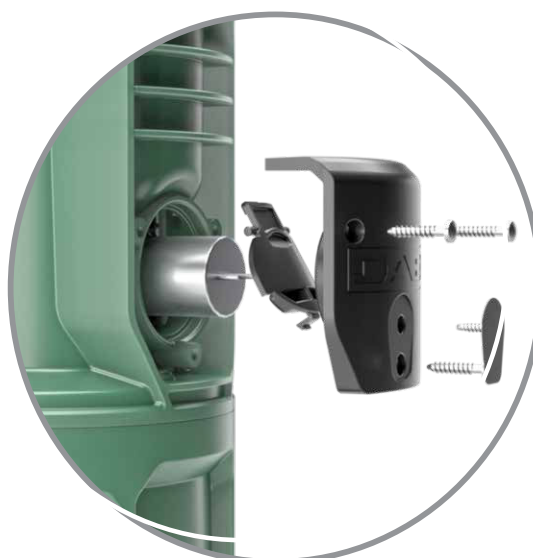

## OVERVIEW

### PRACTICAL TO USE

The new **retractable handle** makes it easier to move the pump, while **the hook** is designed to use a cord when the pump is lowered into a tank or well.

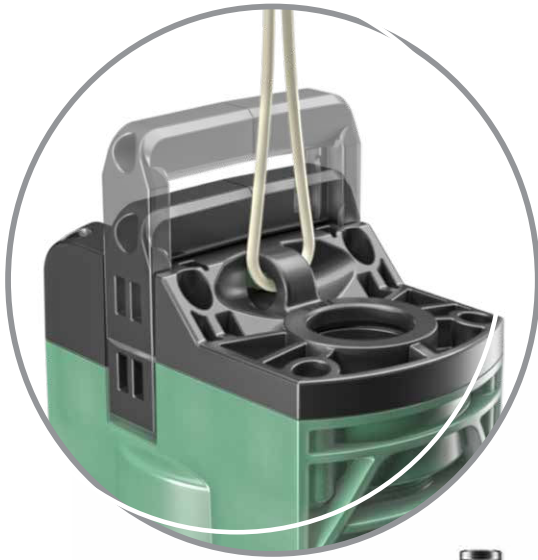

DIVERTRON

# FEATURES

## HIGH EFFICIENCY IMPELLERS

The technopolymer impellers are based on in-depth research into fluid dynamics to increase performance: higher efficiency with lower energy consumption.

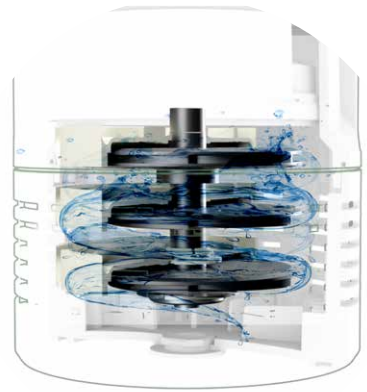

## NEW MOTOR

The motor has been redesigned to reduce consumption. But also to improve performance.

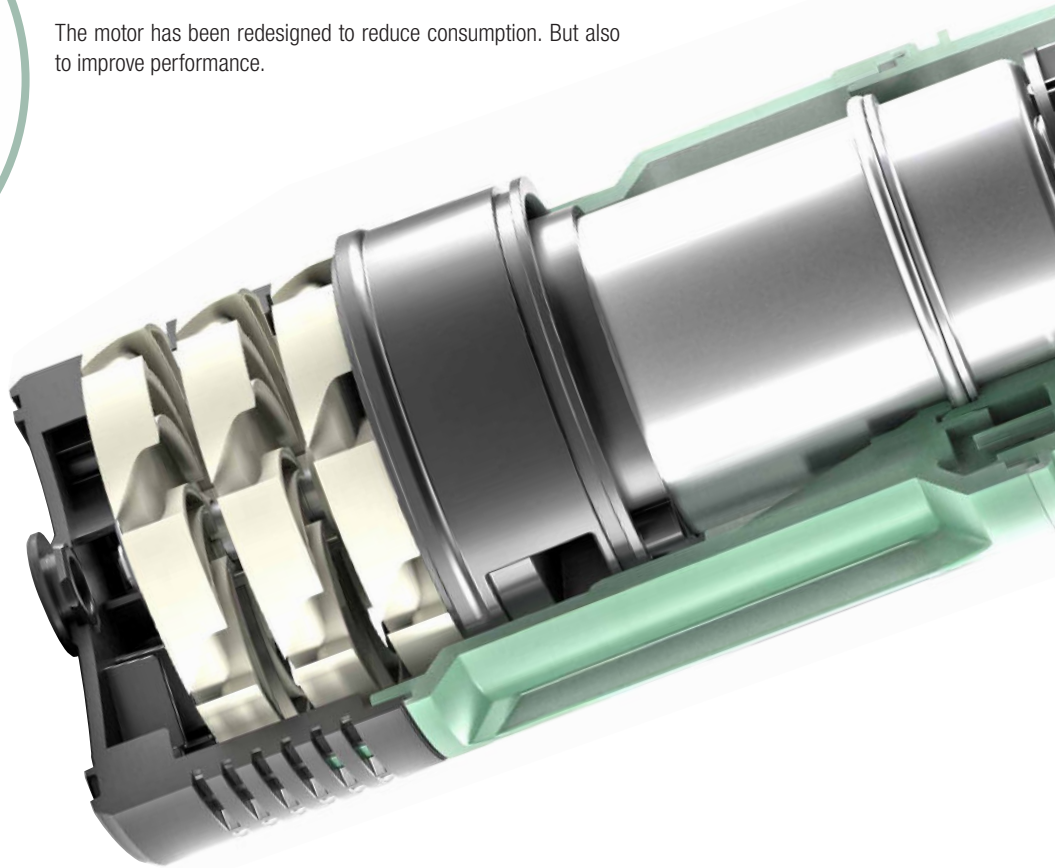

## MECHANICAL SEAL

We have applied a mechanical sealing system that offers two advantages: greater strength and durability, but also greater efficiency, thanks to the combined action with the new hydraulics.



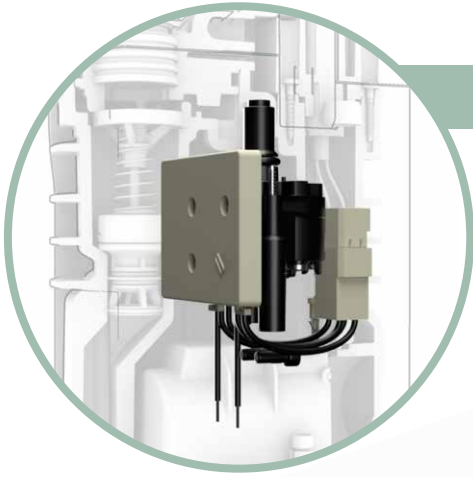

## INTEGRATED ON/OFF ELECTRONICS

The integrated electronic card manages starting and stopping of the pump automatically in relation to the water demand, without the need to install an external controller. This prevents dry running of the pump in the event of a prolonged shortage of water. Easier to install, and easier and safer to use.

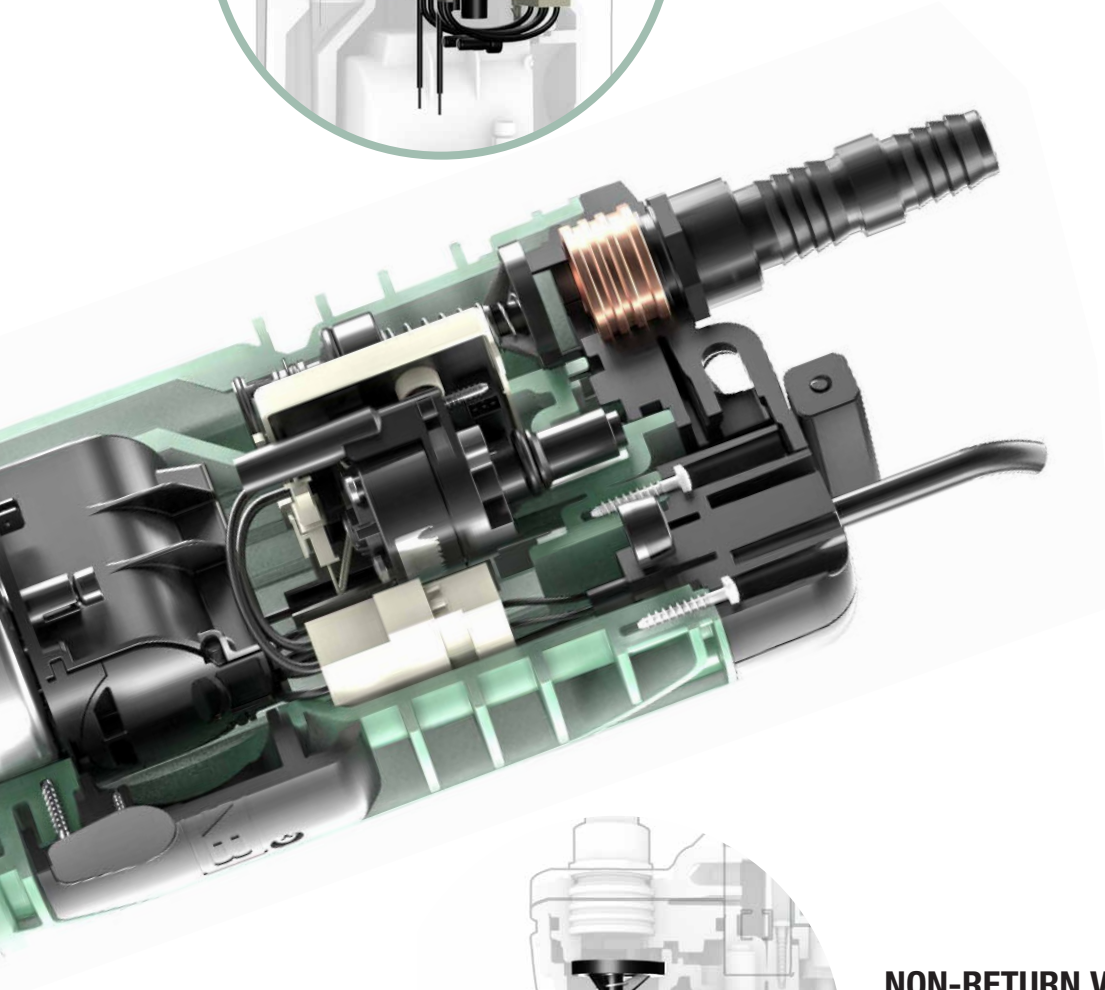

## NON-RETURN VALVE

The non-return valve ensures quick and safe initial installation, allowing immediate priming.

## DIRECT ACCESS TO THE CAPACITOR

The capacitor housing is designed to be replaced quickly without the need to remove the pump housing.



**DIVERTRON**

# SELECTION TABLE



DIVERTRON  
650



DIVERTRON  
900

MAXIMUM  
NUMBER  
OF FLOORS

	MAXIMUM NUMBER OF FLOORS	WATER PRESSURIZATION / RAIN WATER REUSE			IRRIGATION
		SMALL APARTMENT with 1 bathroom (6 taps)	MEDIUM APARTMENT with 2 bathrooms (10 taps)	LARGE APARTMENT with 2 bathrooms + garden (15 taps)	STATIC SPRINKLERS RANGE 4 m  Flow rate: = 6 l/min Operating pressure: 2.4 bar
		MAXIMUM NUMBER OF APARTMENTS			MAXIMUM NUMBER OF SPRINKLERS
DIVERTRON 650	1	3	1	1	9
	2	2	1	0	
	3	1	0	0	
DIVERTRON 900	1	3	1	1	10
	2	2	1	1	
	3	2	1	0	
	4	1	0	0	

\* The table is indicative and based on average values. To ensure optimal sizing, perform a careful assessment of the specific system.

# VERSIONS \*



STANDARD VERSION



WITH FLOAT



X VERSION



Kit X for X Version



\* Recommended installation with auxiliary tank

# TECHNICAL DATA

MAXIMUM FLOW RATE	up to 6 m <sup>3</sup> /h
MAXIMUM HEAD	up to 45 m
P1	up to 920 W
P2 NOMINAL	up to 0,56 Kw (0,75HP)
MAXIMUM IMMERSION DEPTH	12 m
MAX AMBIENT AND LIQUID TEMPERATURE:	+40 °C
FACTORY CUT-IN:	2,4 bar (±0,2)
DELIVERY THREAD:	1"
PUMP MAXIMUM DIAMETER:	160 mm.
DIMENSIONS:	Divertron 650: 487x160 mm Divertron 900: 534x160 mm

