

We have developed this series of field installation guidelines to assist you in correctly installing fixtures and transformers, ensuring customer satisfaction and trouble-free service. If you have any questions, please call your local distributor or the FX TechLine at 800-733-2823 before proceeding. Follow all NEC guidelines and local electrical codes. For more information, visit: fxl.com

TYPICAL INSTALLATION:

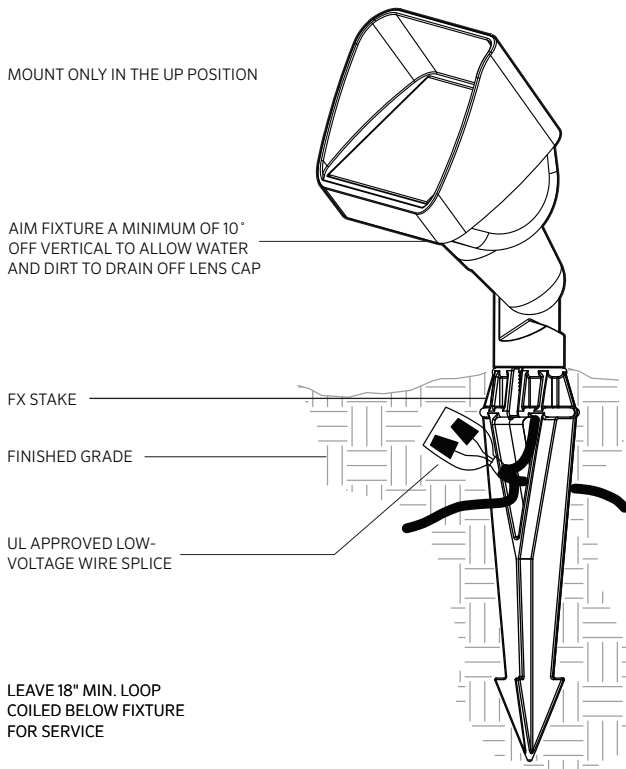

INSTALLATION GUIDELINES:

DO NOT EXCEED 15 VOLTS IN THIS FIXTURE

The LEDs in this product function ideally when the incoming voltage is between 10–15 volts. Voltages outside of this range may damage the LEDs, shorten their life, and cause unsatisfactory performance. **The use of improper voltage voids the product warranty. Only use a UL 1838 approved power supply.**

Changing or removing the color filter:

To replace a color filter on the LC no screw removal is required. Simply pull upwards on the lens cap to remove. Replace the color filter that attaches to the white reflector by pressing back the clips. Replace the lens cap and make sure the cap is fully seated with o-ring intact.

Do not use the LC as a down light. Doing so may cause failure and void of warranty.

The LED board in this product is designed to offer years of use without replacement. Should you have a need to replace the LED board, please contact your local FX distributor.

THE LC IS ONLY FOR USE AS A UP LIGHT. USING IN ANY OTHER POSITION COULD CAUSE POTENTIAL FAILURE.

RISK OF FIRE WARNING: DO NOT USE FX FIXTURES WITH ANY STYLE OF TRANSFORMER THAT EXCEEDS 15 VOLTS ON THE SECONDARY.

SAVE THESE INSTRUCTIONS:

WARNING – To reduce the risk of FIRE OR INJURY TO PERSON:

- Turn off/unplug and allow to cool before replacing lamp.
- Lamp gets HOT quickly. Contact only switch/plug when turning on.
- Do not touch hot lens, guard, or enclosure.
- Keep lamp away from materials that may burn.
- Do not touch the lamp at any time. Use a soft cloth.
- Oil from skin may damage lamp.
- Do not operate the luminaire fitting with a missing or damaged shield.

WARNING – Risk of Electric Shock

- Install all luminaires 10 feet (3.05 m) or more from a pool, spa, or fountain.
- A luminaire shall not use tungsten halogen lamps unless the luminaire is marked for such lamps.

LOW VOLTAGE CABLE SHALL:

1. Be protected by routing in close proximity to the luminaire or fitting, or next to a building structure such as a house or deck;
2. Not be buried except for a maximum 6 inches (15.2 cm) in order to connect to the main low voltage cable; and
3. Have the length cut off so that it is connected to a connector within 6 inches (15.2 cm) from a building structure, a luminaire, or fitting.

If using corrosion protection gel, then pump about two squeezes of gel into a baggie and insert both Listed wirenut connections into it. Push out the air and work the gel into the bottom of the wirenut assuring a waterproof connection. Install the cable tie as shown and cinch down to complete the low voltage connection. It's best to leave 12–18" of slack at each fixture to allow for relocation or if you need to splice in additional cables in the future. Since this is a permanent splice solution—you will need to cut it off and start from scratch to add cables to the splice.

We have developed this series of field installation guidelines to assist you in correctly installing fixtures and transformers, ensuring customer satisfaction and trouble-free service. If you have any questions, please call your local distributor or the FX TechLine at 800-733-2823 before proceeding. Follow all NEC guidelines and local electrical codes. For more information, visit: fxl.com

TRANSFORMERS

Single Transformer

When using only one transformer, it is very important to center the transformer on the wattage load. If the project calls for 135 watts in both front and back yard, the transformer should be centered on the side of the house that will receive the most lighting. A common mistake is to locate the single transformer on the service side of the house or in the garage, which might result in excessively long cable runs to reach lighted areas. The primary goal in laying out low voltage systems is to minimize cable runs because of voltage drop.

Multiple Transformers

A common mistake in laying out multiple transformer circuits is to group several transformers in one location because of utility or visual considerations only. As with any low voltage layout, the prime directive should be to locate the transformers as close to the fixtures as possible in order to minimize cable runs. The other multi-transformer layout consideration is “use zoning”. Having several transformers allows the client to selectively control light in separate areas. This approach is similar to irrigation design in that the goal is to individually control areas that have similar needs. In lighting, a recreation area has different lighting needs than does a front entry. Therefore, the lights that serve these different lighting use areas need to be on separate transformers and switch controls.

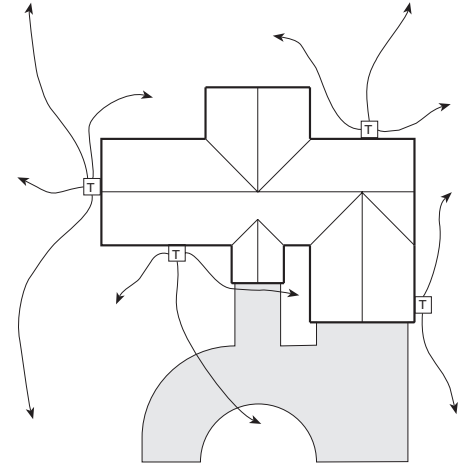

Sample diagram of home with transformer and lamp placement

CIRCUITING GUIDELINES

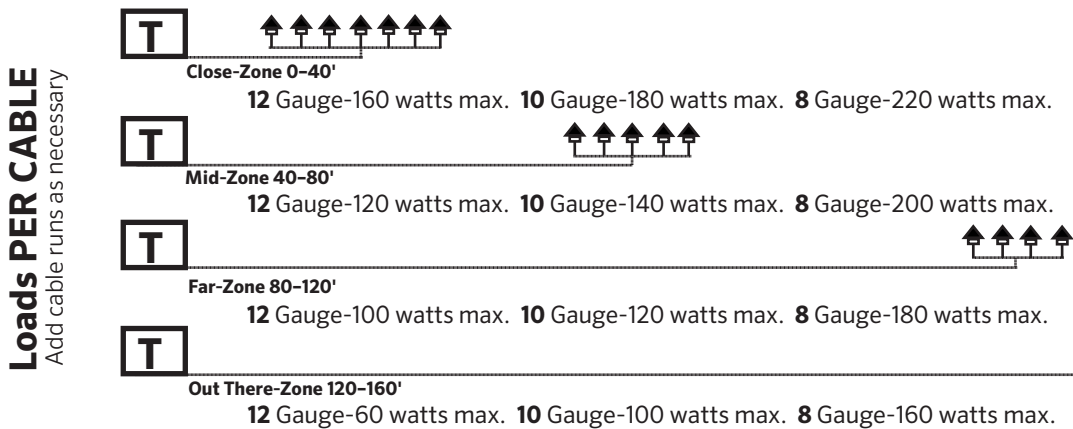

LED LIFE

- For maximum light output, tune lighting circuits to provide between 10 and 15 volts as measured at lamp terminals when all of the lamps on the circuit are operating.
- Voltage can be regulated by adjusting circuit load/run.
- To determine circuit voltage, use a digital voltmeter.