

# Mini Ollo Step Light with Eyelid Installation Instructions



## Product Specifications

Model No.	HV2891W-SS316	HV2891C-SS316	HV2891W-BLK	HV2891C-BLK	HV2891W-CP	HV2891C-CP
Name	Mini Ollo					
Material	316 Stainless Steel		316 Stainless Steel		316 Stainless Steel + Copper	
Colour	Stainless Steel		Black Cover with Stainless Steel body		Copper Cover with Stainless Steel body	
IP Rating	IP67					
Input Voltage	12v DC					
Lamp Base	Built in LED					
Lamp Wattage	1x 1w					
Colour Temp	3000k	5500k	3000k	5500k	3000k	5500k
Lumens	80lm	90lm	80lm	90lm	80lm	90lm
CRI	> 80					
Wiring	Parallel					
Dimmable	No					
Warranty	3 Years Replacement*					

## Dimensions

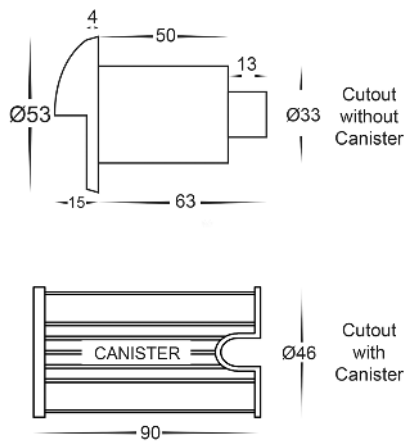

## Sample Wiring Diagram

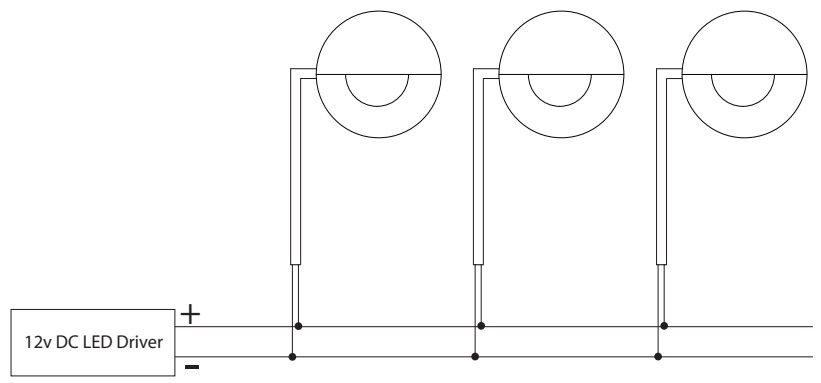

## Important Safety Issues:

- This product must be installed by a qualified electrician according to AS/NZS 3000.
- Ensure all electrical mains are disconnected before any installation.
- Modification of this product will void any warranty.
- Havit Lighting does not take responsibility for wrong installation, incorrect use, or use of installation material that does not belong to the system.
- When installing low voltage fittings, Voltage to fitting must be within +or- 5% of voltage required and cannot be installed more than 25m from LED Driver, if not within this allowance warranty will be voided.
- Aluminium and 304SS fittings must not be installed within 5km of any salt water environments.
- All 316 stainless steel fittings must have regular cleaning maintenance to avoid any tea staining from forming on fitting. (Warranty does not cover Tea Staining)
- When installing copper fittings, gloves must be worn to avoid any oils transferring to fitting.
- All o-rings and seals must be in place correctly to maintain warranty.
- These instructions may be updated at any time due to product improvements, Please visit website for most current installation instructions.

## Steps for Installation:

1. Make sure that the electrical circuit is free of voltage (master switch off)
2. Make a hole where fitting is to be placed using dimensions provided on line drawings,
3. Using an appropriate 12v DC LED Driver - DO NOT CONNECT LIGHT FITTING DIRECTLY TO 240V
4. If installing into concrete, insert canister making sure it is flush with wall.
5. Connect the cable - If more than one fitting installed, wiring must be done in parallel.
6. Strip back the cable on both fitting and cable run and twist the positive cables together. Then connect neutral cables together
7. Solder all joins using solder and either a heat gun or butane gas torch.
8. Cover connections using an adhesive lined heat shrink or gel cap to make connection watertight. Failure to do this will void warranty.
9. Heat the heat shrink or crimp the gel cap making sure all connections are covered.
10. Insert fitting into hole or canister
11. Apply silicon around edge of fitting to prevent any water from getting inside to electrical connections.
12. All connections must be carried out carefully, inspect all contacts before switching back on the electric circuit.

## Must be installed by a licensed electrician

### Contact Details:

143 Beauchamp Road  
Matraville NSW 2036  
Australia  
Tel: 02 9381 8300  
Fax: 02 9666 8881  
Email: sales@havit.com.au  
Web: www.havit.com.au

### Warranty Terms & Conditions\*



### Additional Information

