

PRODUCT DATA SHEET

BIA-AUTOSUB • 810335



BRAND

**BIANCO
PUMPZ**

PRODUCT DETAILS

The Bianco AUTOSUB Submersible Pump is specially designed and manufactured for the rainwater industry.

Being a submersible design means that the pump can be placed inside the rainwater tank for a neat, secure and quiet installation.

It is intended for use in household applications for the automatic supply of clean water which contains no fibres.

APPLICATIONS

- Household water supply
- Gardening
- Drinking water
- Household water supply

FEATURES

- Compact
- Easy to install and use
- Automatic on/off
- Intelligent controller
- Dry-run protection
- Water cooled motor

TECHNICAL DATA

RATED POWER (W)	750
MAX. FLOW [LPM]	100
MAX. FLOW [M3/H]	6
MAX. HEAD [M]	45
MOTOR PROTECTION LEVEL	Class F
PROTECTION CLASS	IPX8
WORKING TEMPERATURE	-5°-40°C
LIQUID TEMPERATURE	0°C-35°C
MAX. DIVING DEPTH	12m
MAX. DIA. OF PARTICLE	1mm
MOTOR	Heavy Copper winding
MAX DEPTH OF IMMERSION	12m
OUTLET	1"

RATED VOLTAGE	220V-240V
RATED CURRENT	2.5A @ 230V
POWER CABLE TYPE	H07RN-F
LENGTH OF POWER CABLE	10m
PROTECTION CLASS	IPX8
IMPELLERS	4
OUTLET	G1
FILTER	Y
PACKAGE DIMENSION	260x215x565mm
GROSS WEIGHT (KG)	11.6
AUTOMATION FUNCTION	ISENSOR Auto Control + Fixed Arm Float Switch
MAX DEPTH OF IMMERSION	12m
OUTLET	1"

CURVE

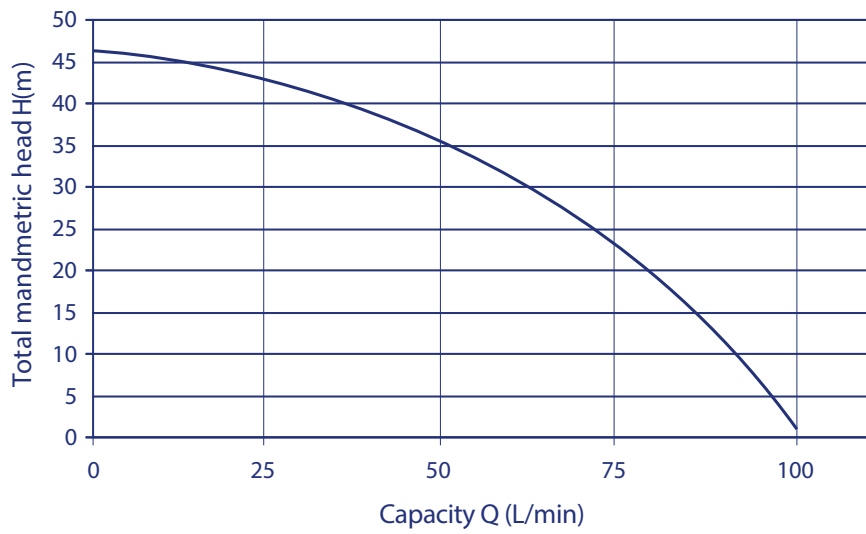

BIA-AUTOSUB & BIA-AUTOSUBX

DIMENSIONS

DIMENSIONS (mm)

251 x 492

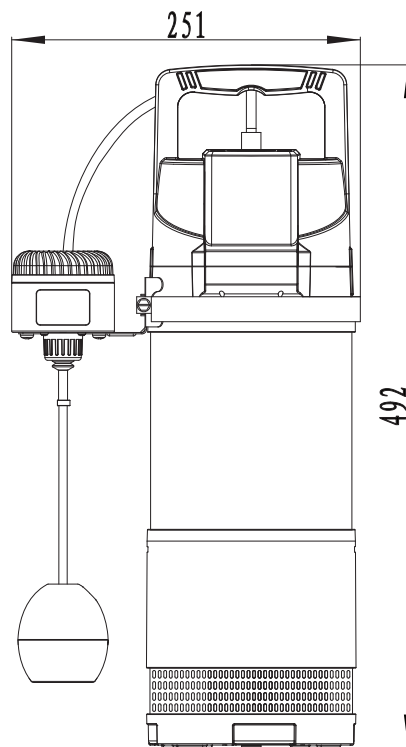

DIAMETER (mm)

159

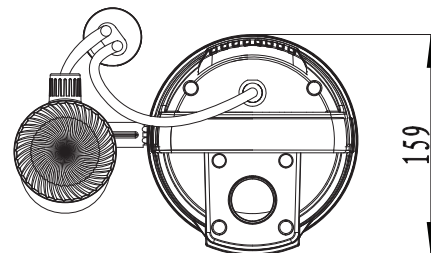

WARRANTY / CERTIFICATIONS

