

# AcquaSaver®



## Water Diversion Valve

Hydraulically Operated  
Solid Brass Construction  
Built-in Dual Check Valves



WaterMark  
ATS 5200.477  
WMK 60075  
AGA

# AcquaSaver®

The AcquaSaver® Valve is a fully automatic mechanical rainwater/mains water changeover device designed for pressure pump supply systems for harvesting rainwater for the toilet, laundry and household applications with automatic mains backup.

It is suitable for up to 2 toilets and washing machine and an extra tap outlet.

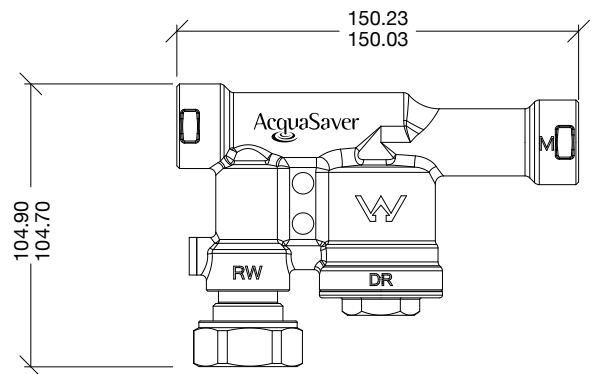

## Features

- Easy to install
- Patent design
- Solid Brass mounting bracket (optional)
- Watermark approved to ATS/NZS 5200.477
- Does not require regular maintenance
- No electrical consumption - No electronic components
- Solid brass construction - Fully weatherproof - Built to last
- Suitable for any pressure pump with sufficient head pressure
- Can be mounted in any position
- Built-in dual check valve for backflow prevention
- 2 Year warranty

## Specifications

Max Mains Pressure	500 KPa
Max Pump Pressure	600 KPa
Min Pump Pressure	300 KPa
Max Flow Rate	50 LPM
Max Water Temperature	40 C
Min Water Temperature	0 C
Pump Inlet	25mm 1" BSP F
Mains Water in	20mm 3/4" BSP F
Outlet	20mm 3/4" BSP F
Weight	0.85 KG

Complies to AS/NZS 3500.1 when installed by a licensed plumber.



**WaterMark**  
ATS 5200.477  
WMK 60075  
AGA

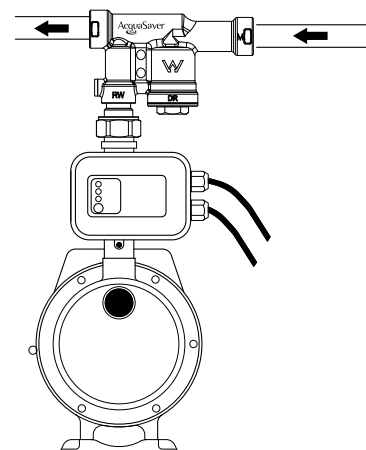

available from:

**PROUDLY  
MANUFACTURED  
BY**



**BELTRAMI  
GROUP**

18-20 Cottage Street,  
Blackburn, VIC 3130, Australia  
+61 3 98 78 15 75

+61 3 98 94 28 20  
info@beltrami.com.au  
www.beltrami.com.au

