

Tivah Aluminium Black Up & Down Wall Lights



Product Specifications

Name	Tivah
Material	Aluminium
Colour	Poly Powder Coated Black
IP Rating	IP65
Installation Type	Wall - Surface Mounted
Lamp Base	Either GU10 or MR16
Protection Class	240v = 1 (Requires Earth)
	12v DC = 3 (No Earth Required)
Max Wattage	2x 35w GU10 2x 20w MR16
Lamp Expectancy	>30,000hrs
Diffuser Type	Clear Glass
UGR	<32
CRI	CRI>80
Dimmable	No - Not with supplied globes, See below for optional dimmable globes
IK Rating	IK10
Warranty	3 Years Replacement*



Optional Havit Compatible Accessories

Image	Part Number	Colour Temp	Input Voltage	Beam Angle	Included LED
	HV9506D	3000k 4000k 5500k	240v AC	60°	TRI Colour 3/5/7w GU10 LED
	12v DC LED Drivers	See Catalogue or Website for full range of 12v DC LED Drivers			

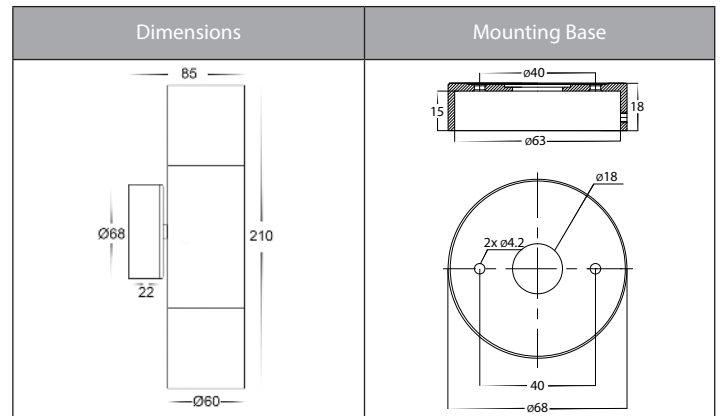

Product Ordering

Part Number	Colour Temp	Lumens	Input Voltage	Beam Angle	Included LED	Barcode
HV1025T	3000k 4000k 5500k	2x 240-560lm 2x 255-595lm 2x 270-630lm	240v AC	60°	 TRI Colour 2x 3/5/7w GU10 LED	9350418014825
HV1027GU10T	3000k 4000k 5500k	2x 270lm 2x 285lm 2x 300lm	240v AC	120°	 TRI Colour 2x 5w GU10 LED	9350418014832
HV1027MR16T	3000k 4000k 5500k	2x 270lm 2x 285lm 2x 300lm	12v DC	120°	 TRI Colour 2x 5w MR16 LED	9350418014849

*Items ordered after 01-01-2022

